

Product Features

<b>Series Category</b>	YZG-XG; YZG-XB/BT; YZG-KB; YZG-SG; YZG-SB/SBT; YZG-LG											
<b>Bore of Cylinder (mm)</b>	Φ25				Φ32		Φ40		Φ50		Φ63	
<b>Piston Rod Diameter(mm)</b>	Φ18				Φ20		Φ22.4		Φ28		Φ35	
<b>Rotation Angle</b>	30°±3	45°±3	60°±3	90°±3	30°±3	45°±3	60°±3	90°±3	30°±3	45°±3	60°±3	90°±3
<b>Full Stroke (mm)</b>	17	18.2	19.5	22	20.2	21.7	23.1	26	24	25.5	27	30
<b>Rotation Stroke (mm)</b>	4	5.2	6.5	9	5.2	6.7	8.1	11	7	8.5	10	13
<b>Clamping Stroke (mm)</b>	13				15				17			
<b>Extended Full Stroke (mm)</b>	-	-	-	-	35.2	36.7	38.1	41	41	42.5	44	47
<b>Extended Rotation Stroke (mm)</b>	-	-	-	-	5.2	6.7	8.1	11	7	8.5	10	13
<b>Extended Clamping Stroke (mm)</b>	-	-	-	-	30				34			
<b>Pressure Area Pull-in/Push-out (cm<sup>2</sup>)</b>	2.37/4.91				4.9/8.04		8.63/12.57		13.47/19.63		21.55/31.17	
<b>Theoretical Clamping Force (30KN/cm<sup>2</sup>)</b>	71				147		259		404		647	
<b>Maximum Operating Pressure (KN/cm<sup>2</sup>)</b>	100											
<b>Operating Pressure Range (KN/cm<sup>2</sup>)</b>	15-70											

Precautions for Installation and Use

Schematic diagram of vertical and angular stroke

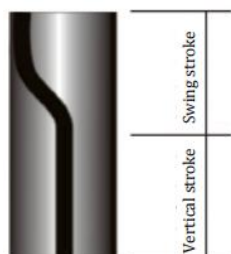

Clamping arm locking and disassembling method



Remark:

- Please read the installation and operation instructions carefully before using this product.
- If you need to lengthen the clamping arm, please do not exceed 1.5 times the standard length.
- Please do not clamp the workpiece at the corner stroke section when the clamping arm is descending.
- Please filter your intake (hydraulic) source to avoid damaging the seals in the cylinder
- The working pressure you use should not exceed the maximum allowable working pressure of the product.
- The angle accuracy of the swing clamp cylinder is ±1°.

YZG-XG/oil pressure lower flange piping swing clamp cylinder

Pressure Range
15-70KN/cm <sup>2</sup>



**High quality seals**  
High quality seals are used to effectively prevent coolant and chips from entering the cylinder block.

**High precision taper fit**  
The taper fit is adopted between the clamping arm and the piston, which not only facilitates disassembly, but also ensures the positioning accuracy, and you can freely adjust the angle of the clamping arm to meet your requirements.

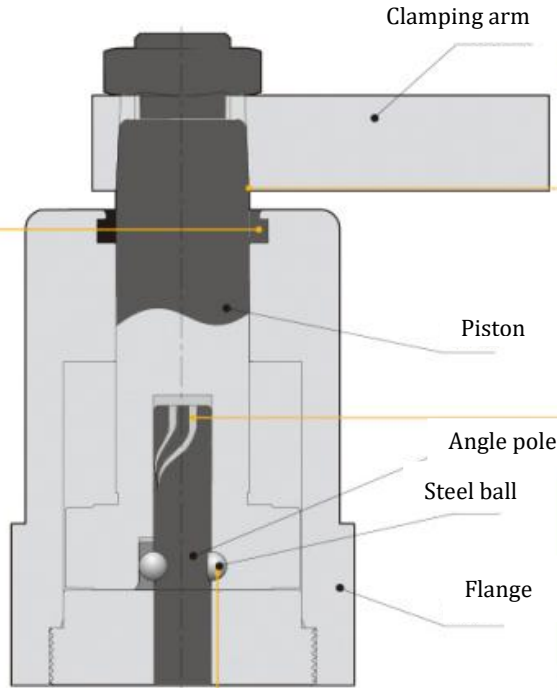

**Point steel ball support**  
Three-point steel ball support mechanism is adopted to realize stable high-speed rotation.

**Gothic cam groove**  
Gothic cam groove with large contact surface with steel ball is adopted to effectively reduce the pressure on the contact surface and rotate continuously at high speed with high frequency.

The figure shows the sectional view of the YZG-XG clamping state

Model Representation

YZG-XG ① ② ③ \* ④ (Example: YZG-XG25SR\*90)

YZG-XG

① Dimension (refer to specification sheet) ② Clamping arm

- 25
- 32
- 40
- 50
- 63

S: single side  
D: double side

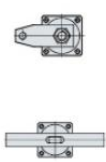

③ Rotation direction (during clamping) ④ Rotation angle

L: turn left  
R: turn right

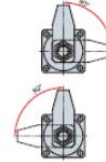

- 0: Rotation angle 0°
- 45: Rotation angle 45°
- 60: Rotation angle 60°
- 90: Rotation angle 90°

(The above is the standard model and the extended stroke type is expressed as: "YZG-XG①②③④JC")

Piping Method

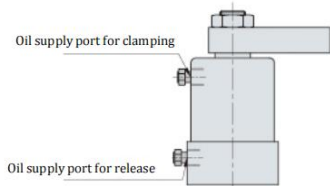

Piping type (without plate interface)  
The figure shows the clamping state of KZG-XG

Rotation Angle (When Clamped)

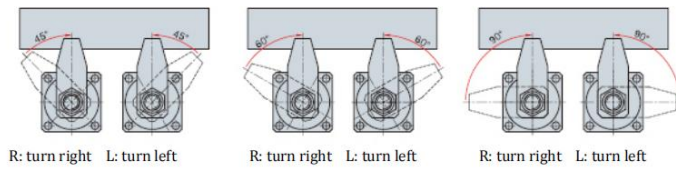

R: turn right L: turn left

R: turn right L: turn left

R: turn right L: turn left

Product Type

Standard type

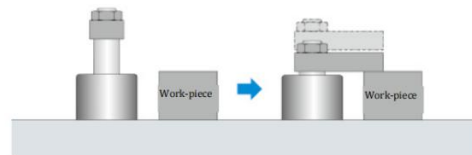

Extended stroke type

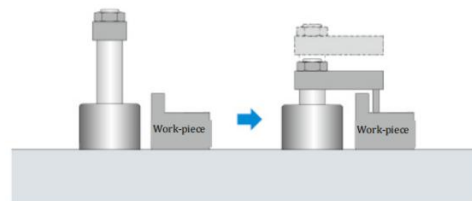

Action Description

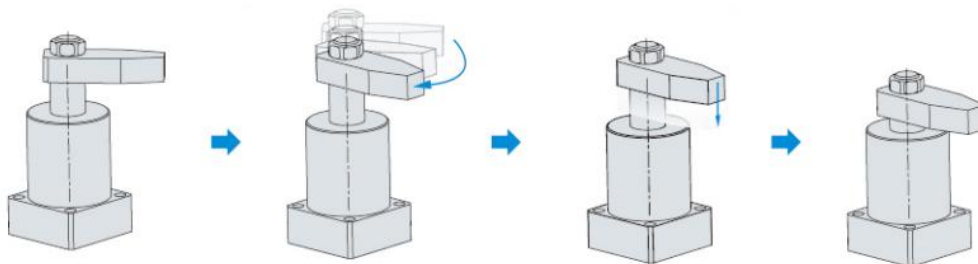

Before rotation (released state)

Rotate while descending

Continue to descend after rotation ends

Action ends (clamping state)

Overall Dimension

Single-sided clamping arm XG

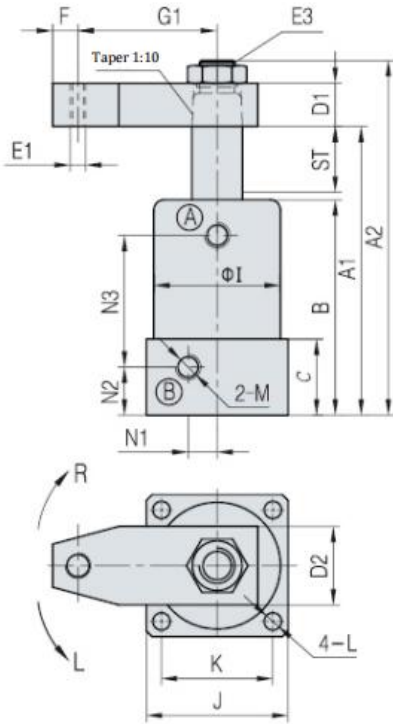

Double-sided clamping arm XGD

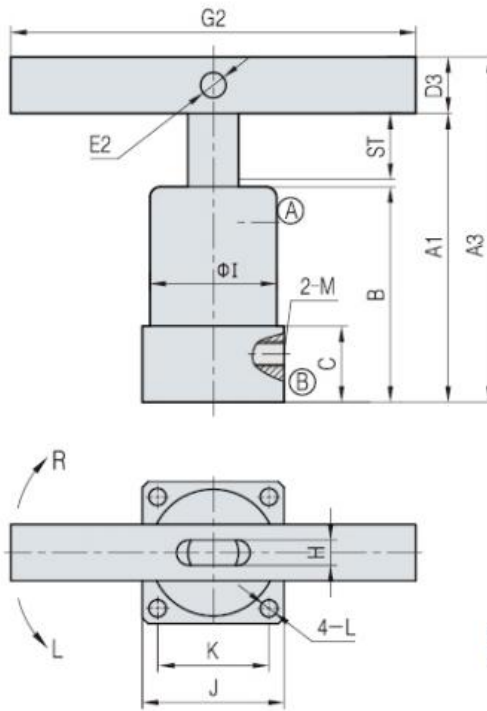

A-clamping hole  
B-release hole  
The figure shows the released state

Model	YZG-XG25	YZG-XG32	YZG-XG40	YZG-XG50	YZG-XG63				
ST:Swing/clamping	22(9/13)	26(11/15)	41(11/30)	26(11/15)	41(11/30)	30(13/17)	47(13/34)	30(13/17)	47(13/34)
A1	101	115	145	120	150	134	168	139	173
A2	(125)	(140)	(170)	(149)	(179)	(167)	(201)	(178)	(212)
A3	120	137.2	167.2	142.2	172.2	159.4	193.4	170.8	204.8
B	76	85	100	90	105	100	117	105	122
C	27	30	30	30	30	34	34	34	34
D1	15	17	17	18	18	20	20	23	23
D2	27	31	31	31	31	37	37	48	48
D3	□19	□22.2	□22.2	□22.2	□22.2	□25.4	□25.4	□31.8	□31.8
E1	M10*1.5	M10*1.5	M10*1.5	M10*1.5	M10*1.5	M12*1.75	M12*1.75	M16*2	M16*2
E2	Φ8	Φ8	Φ8	Φ10	Φ10	Φ12	Φ12	Φ15	Φ15
E3	M14*1.5	M16*1.5	M16*1.5	M18*1.5	M18*1.5	M20*1.5	M20*1.5	M27*1.5	M27*1.5
F	10	10	10	10	10	12	12	15	15
G1	50	55	55	60	60	65	65	75	75
G2	140	160	160	160	160	180	180	200	200
H	9	10	10	10	10	12	12	15	15
ΦI	Φ46	Φ50	Φ50	Φ54	Φ54	Φ66	Φ66	Φ80	Φ80
J	52	56	56	63	63	72	72	88	88
K	40	44	44	48	48	57	57	70	70
L	Φ6.8	Φ6.8	Φ6.8	Φ9	Φ9	Φ9	Φ9	Φ11	Φ11
M	RP1/8	RP1/8	RP1/8	RP1/8	RP1/8	RP1/4	RP1/4	RP1/4	RP1/4
N1	8	10	10	12	12	15	15	17	17
N2	16	19	19	19	19	21.5	21.5	22	22
N3	45	52	67	57	72	63.5	80.5	59	76

Note: □ indicates square

Performance Table

The clamping force varies depending on the length of the clamping arm (G1) and the oil pressure. Please comprehensively consider the clamping arm length (G1), operating oil pressure, installation size and other factors to select the appropriate swing clamp cylinder model.

Note: the longer the clamping arm of the swing clamp cylinder, the greater the force acting on the cam mechanism. Do not use a clamping arm longer than the maximum length (Max.G1)

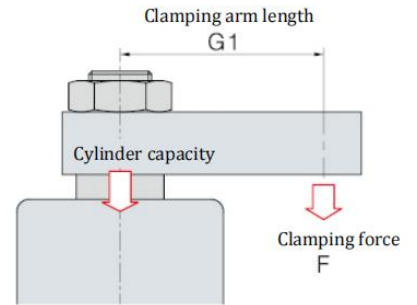

Interpretation of clamping force

When YZG-XG32 is used, the supplied oil pressure is 5.0MPa and the clamping arm length is 65mm, the clamping force is about 1.7kN.

F: clamping force (KN) P: operating oil pressure (MPa) G1: clamping arm length (mm)

YZG-XG25				
Oil pressure (MPa)	Cylinder capacity (kN)	Clamping force (kN)		
		Clamping arm length G1 (mm)		
		50	60	70
7.0	1.7	1.3	1.2	1.1
6.5	1.5	1.1	1.1	1.0
6.0	1.4	1.1	1.0	0.9
5.5	1.3	1.0	0.9	0.9
5.0	1.2	0.9	0.9	0.8
4.5	1.1	0.8	0.8	0.7
4.0	0.9	0.7	0.6	0.6
3.5	0.8	0.6	0.6	0.5
3.0	0.7	0.5	0.5	0.5
2.5	0.6	0.5	0.4	0.4
2.0	0.5	0.4	0.4	0.3
1.5	0.4	0.3	0.3	0.3

YZG-XG32					
Oil pressure (MPa)	Cylinder capacity (kN)	Clamping force (kN)			
		Clamping arm length G1 (mm)			
		55	65	75	85
7.0	3.4	2.6	2.5	2.5	2.4
6.5	3.2	2.3	2.3	2.3	2.2
6.0	2.9	2.2	2.1	2.0	1.9
5.5	2.7	2.0	1.9	1.9	1.8
5.0	2.4	1.8	1.7	1.6	1.6
4.5	2.2	1.6	1.5	1.5	1.4
4.0	2.0	1.5	1.4	1.4	1.3
3.5	1.7	1.2	1.2	1.2	1.1
3.0	1.5	1.0	1.0	1.0	0.9
2.5	1.2	0.8	0.8	0.8	0.7
2.0	1.0	0.6	0.6	0.6	0.5
1.5	0.7	0.4	0.4	0.4	0.4

YZG-XG40					
Oil pressure (MPa)	Cylinder capacity (kN)	Clamping force (kN)			
		Clamping arm length G1 (mm)			
		60	70	80	90
7.0	6.0	4.4	4.3	4.1	4.0
6.5	5.6	4.1	4.1	4.0	3.7
6.0	5.2	3.8	3.7	3.6	3.4
5.5	4.7	3.5	3.4	3.3	3.1
5.0	4.3	3.1	3.1	3.0	2.8
4.5	3.9	2.8	2.7	2.7	2.5
4.0	3.5	2.5	2.4	2.4	2.2
3.5	3.0	2.2	2.1	2.0	1.9
3.0	2.6	1.8	1.7	1.7	1.6
2.5	2.2	1.5	1.4	1.4	1.3
2.0	1.7	1.2	1.1	1.0	1.0
1.5	1.3	0.8	0.8	0.7	0.7

YZG-XG50					
Oil pressure (MPa)	Cylinder capacity (kN)	Clamping force (kN)			
		Clamping arm length G1 (mm)			
		65	75	85	95
7.0	9.4	7.1	6.8		
6.5	8.8	6.8	6.3	5.4	
6.0	8.1	6.0	5.6	5.3	
5.5	7.4	5.5	5.3	5.1	4.3
5.0	6.7	5.0	4.8	4.7	4.2
4.5	6.1	4.4	4.3	4.3	4.0
4.0	5.4	3.9	3.9	3.7	3.6
3.5	4.7	3.3	3.4	3.3	3.0
3.0	4.0	2.8	2.8	2.7	2.7
2.5	3.4	2.3	2.3	2.2	2.1
2.0	2.7	1.7	1.8	1.8	1.6
1.5	2.0	1.1	1.3	1.3	1.1

YZG-XG63					
Oil pressure (MPa)	Cylinder capacity (kN)	Clamping force (kN)			
		Clamping arm length G1 (mm)			
		75	90	100	110
7.0	15.1	9.6	9.1	6.3	
6.5	14.0	9.3	8.9	6.2	5.8
6.0	12.9	8.8	8.3	6.0	5.4
5.5	11.8	8.1	7.5	5.9	4.9
5.0	10.8	7.4	7.0	5.8	4.7
4.5	9.7	6.6	6.2	5.6	4.4
4.0	8.6	5.9	5.5	5.3	4.3
3.5	7.5	5.1	4.7	4.6	4.2
3.0	6.5	4.4	4.1	3.8	3.6
2.5	5.4	3.5	3.4	3.1	2.9
2.0	4.3	2.6	2.5	2.3	2.4
1.5	3.2	1.9	1.7	1.5	1.5

\*Precautions:

1. This figure shows the actual measured values. The clamping force at the clamping point of the clamping arm of the standard cylinder is about 65% of the theoretical value.
2. The clamping arm with a large moment of inertia may not be able to rotate due to the supplied oil pressure, flow rate, and installation state of the clamping arm.
3. This figure shows the relationship between clamping force and supplied oil pressure.
4. The clamping force indicates the clamping energy when the clamping arm is clamped at the horizontal position.
5. The clamping force varies with the length of the clamping arm. Use it with the supplied air pressure suitable for the length of the clamping arm.
6. If you need a clamping arm other than our standard, please contact us.

Adjustment of Rotation Speed

1. Please use the flow control valve to adjust the rotation speed so that the relationship between the inertia torque of the clamping arm and the time required to rotate 90° is located below the line “—” of the curve. The time required to rotate 90° does not include the time of clamping stroke (vertical action).

2. If a 90° rotation time shorter than the line “—” is selected, the fault will be caused by the overload of the cylinder and piston.

Calculation example of inertia torque:

$$I = \frac{1}{12}m_1(4A_1^2+B^2) + \frac{1}{12}m_2(4A_2^2+B^2)$$

I: Inertia torque (kg • m<sup>2</sup>)

m: Mass (kg)

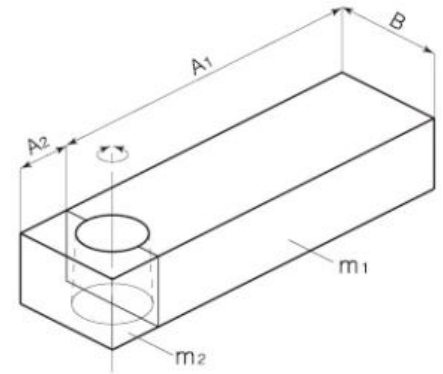

YZG-XG25

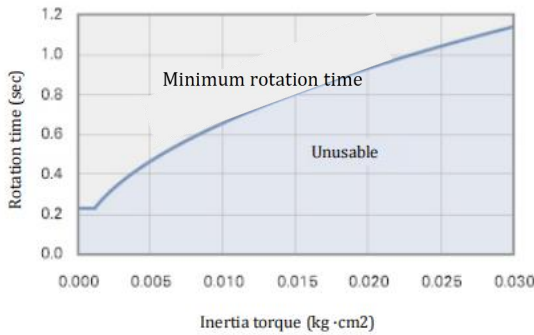

YZG-XG32

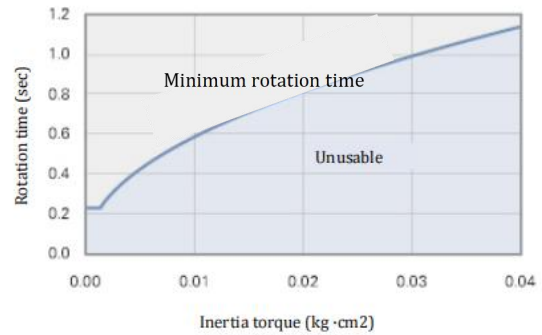

YZG-XG40

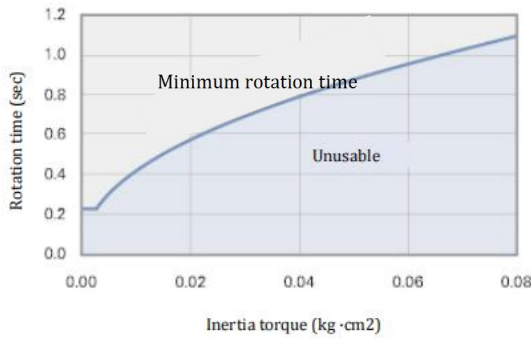

YZG-XG50

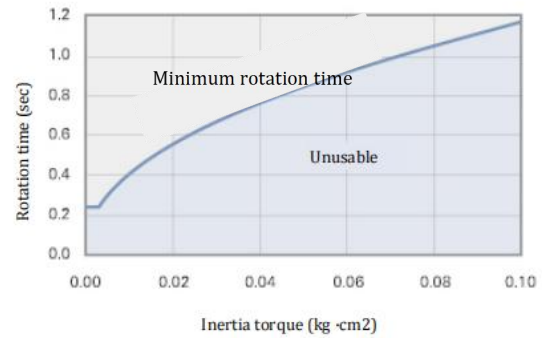

YZG-XG63

